

# Cloning Natural Fibers

By Van Durrett, Vice President and General Manager

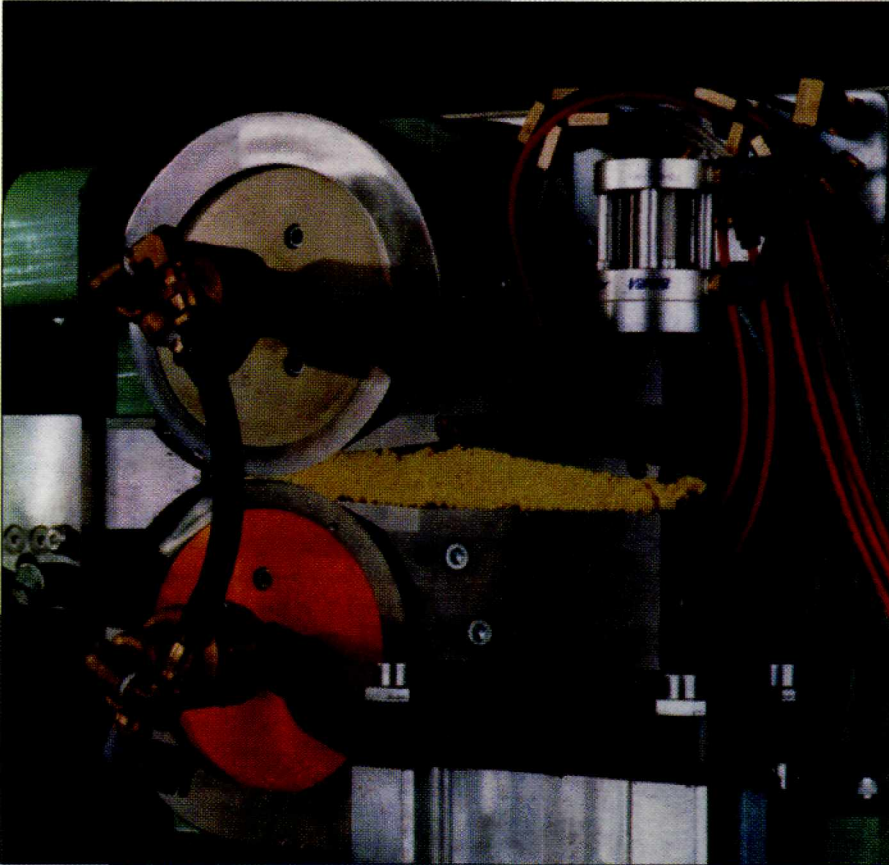

Several years ago in a college entrance exam, more than half the high school seniors failed to note that nylon is an artificial fiber. So accepted has synthetic fiber become that many people do not realize that it has a very short history when compared to natural fibers. For thousands of years man clothed himself, made rope, printed on, and used fiber in innumerable ways to better his life. Fiber processing has been refined during these centuries, but only within the last seventy-five years has there been a new fiber to process. While synthetic continuous filament fiber offers properties that no natural fiber can hope to possess, most synthetic staple fiber seeks not only to better the properties of natural fibers, but to fit into established processes. The man-made fibers must look like natural fibers to the cards and spinning frames. To this end, the staple fiber producer

seeks a product in which all individual fibers are identical. This allows his customers to fine tune their equipment and manufacture a product in which each production run is identical to the last.

The manmade fiber customer has become a connoisseur of fiber. He demands particular fiber characteristics and dictates to the producer minute changes in his supply so that his product will be of top quality. When the fiber producer tailors fiber to a particular end use, he finds that he must control his process and quality so that his fiber strikes an ever diminishing target.

## **The Simple Becomes the Complex**

Manufacturing continuous filament fiber reduces much of the process to measurable scientific process variables, and the resulting fiber is closely monitored to insure that objective values are attained. Fiber tenacity, elongation, melt viscosity,

filament count, and total denier are readily measured and verified.

For the staple fiber producer, life is not quite so simple. His vocabulary includes many subjective terms. Openness, hand, fiber cohesion (or dispersion), and dyeability all haunt his processes.

Filament fiber producers maintain control of their process and can accurately measure quality until the last step. Then the continuous fiber, which has been controlled and nurtured through each step, is turned over to equipment that sometimes seems as if it has a diabolical mind of its own.

This equipment must take the fiber producer's beautiful straight continuous fiber, wrinkle it, and cut it, so his customer will have a much easier task convincing his equipment it is processing the same fiber it has always processed. It seems simple at first, to wrinkle the fiber and then cut it. But as in most things that seem simple, the difficulty lies in the execution.

## **Using a Crimper to "Wrinkle" Fiber**

Most manmade staple today is "wrinkled" with a stuffing box crimper and cut with a radial blade cutter. The stuffing box crimper has been in existence for over seventy-five years. There are and have been other processes to induce texture into manmade fiber, but the stuffing box crimper alone offers the capability to process volumes of fiber at economical production rates.

At first glance, the crimper seems simple enough. All one needs is two rolls and a chamber into which to force the fiber, with some method of controlling the back pressure in the chamber. A fiber bundle is gripped between two rolls and forced into a small chamber or stuffing box. As the box fills, friction prevents the fiber from exiting readily. Back pressure controls the friction. The individual filaments begin to behave as columns and buckle between the irresistible urging of the rolls and the fiber trapped in the stuffing box. The crimper appears to act continuously, but in fact operates in a series of small

## Crimper Design

movements of the stuffed fiber within the box. The only continuous part of the operation is stuffing the box with the fiber by the two rolls.

It has been said that science is used to build a crimper, but art is required to operate it. Both art and science are used to build a crimper, art is used to operate it, science is used to evaluate the results, and patience is necessary to maintain it.

### *Roll Size:*

The best crimpers have small roll diameters. Small rolls give a rapidly enlarging opening into the stuffing box. This allows the doctor blades to be structurally compact for greater strength.

If small rolls are good, why don't most crimpers have them? The answer is bearing life. Roll bearings cannot be a larger diameter than the rolls them-

selves. Bearings and roll sizes are balanced by the designer to give the best compromise of life versus performance.

### To Cantilever or Not?

Cantilevered rolls offer superior stuffing box accessibility to the operator, but aggravate bearing problems by taking most of the nip force on the bearing nearest the roll. Dual bearing supported rolls split the nip load between the bearings on either side of the roll.

Because of concerns about bearing life and roll deflection, cantilevered roll crimpers are generally limited to less than 3 inch (75 mm) roll widths. For wider crimpers, the user sacrifices accessibility to gain increased bearing life with dual bearing rolls.

An emerging requirement in speciality crimping applications is the capability for high speed thread-up. This has led to the development of easy opening/closing stuffing box technology. On a cantilevered roll crimper, the outer side plate can be quickly opened and closed to facilitate thread-up. What's Box Geometry?

The heart of any crimper is the stuffing box. Stuffing box design is the art in crimper design. Every crimper manufacturer always asks the customer, "What stuffing box geometry do you require?" The manufacturer's hope is that the customer will assume responsibility for the art. Length, width, and height of the stuffing box ultimately determine the characteristics of the crimped fiber. Beware of crimper manufacturers that offer a "one size fits all" stuffing box. Let's look at each of these dimensions and see what happens.

Remember, friction in the stuffing box generates pressure at the rolls to cause the fibers to buckle. Very short length stuffing boxes require that the pressure control system exert considerable force on the stuffed fiber. Very long stuffing boxes are sensitive to slight changes in back pressure.

The key to maintaining crimp levels with specified characteristics is accurate control of resistance to fiber passage through the stuffing box. Properly sized precision pneumatic regulators and low friction air cylinders are required for most modern crimping applications.

Width is determined by the amount of fiber to be processed. At the center-line of the stuffing box, the fiber is contained laterally by the fiber on either side. At the edges of the stuffing box, it is contained by the side plates. Within

# SPECIALISTS III

Tow cutting is not a sideline at DM&E. We know its importance because we are specialists in the field.

That's how we've built process and maintenance solutions into our equipment, and why we can produce quality cuts as short as 1/8" (3mm).

We offer three series of tow cutters. 40 series for samples or light production. Capacity to 500,000 denier—speeds to 800M/M  
60 series with capacities to 3,000,000 denier— speeds to 450M/M  
90 series for large capacities to 6,000,000 denier— speeds to 470M/M

Our 200 and 300 Series Tension Stands meet the tow tensioning requirements of the fiber processor.

For over 15 years we have provided customers with cutter reels, retrofits, modifications, and repairs for all makes of cutters.

For tow cutting quality demanded by you and your customers, look to DM&E—the industry standard.

**DM&E** CORPORATION

P.O. Box 580, Shelby, NC 28151-0580  
Phone 704/482-8876 • FAX 704/484-8326

certain limits, if you want to process more fiber, simply make the box wider. If the stuffing box is too wide, the fiber will not fill the box width, and will not be contained laterally. Irregular low crimp is the result. As a guideline for textile and general processing, use 250,000 denier per inch of width; for specialized fine crimping, use denier as low as 30,000 per inch of width.

The height of the stuffing box is determined by product characteristics. Tall stuffing boxes induce secondary, and tertiary folding of the crimped fiber. Very short height boxes eliminate this folding but greatly limit throughput as pressure control becomes difficult. We would expect general use crimpers to have box heights from 1 inch (25 mm) to 2 inches (50 mm). Crimpers used for fine crimping with a minimum of secondary folding are found with box heights as small as 3/16 inch (5 mm). Temperature Regulation

Many crimpers feature internal passages in the stuffing box to introduce steam or hot air into the compressed crimped fiber. Others may use cooling passages instead to prevent excessive temperature in the stuffing box.

Rolls may be temperature regulated. Generally water is circulated through the rolls to maintain a suitable surface temperature. There are occasions where it may be necessary to circulate a fluid through the rolls at a carefully controlled temperature to maintain absolute dimensional stability of the rolls. This is particularly true on very wide crimpers.

Preheating will aid in attaining desired levels of crimp in thermoplastic fibers. Steam chambers are frequently placed immediately prior to the crimper for this purpose. Wear Plates

The area of highest pressure in the stuffing box occurs just past the nip point of the two rolls. If the fiber is not restrained in this area, it will escape the stuffing box. Expendable wear plates, usually called "thrust pads" or "cheek plates" are pressed to the roll sides to provide zero clearance. A great deal of wear may be expected from the continuous friction of the fiber against these plates.

Cheek plates may be fixed in position or rotate. Rotation spreads wear over the entire surface of the cheek plate, increasing its useful life.

Construction Materials

Bearing grade stainless steel and tool

steels are found in most roll construction touching. The clearances are usually less and the "tires" are frequently than the thickness of this page. This requires replaceable.

All parts of the stuffing boxes are location of all components. Supports are heat treated stainless steel. In sophisti- usually heavy castings of ductile iron or cated crimpers, the replaceable doctor stainless steel.

blades tips are softer than the roll material Expendable cheek plates are made from a to prevent damage to the rolls in case of variety of materials, selected for compatibility accidental contact. with the roll surface and fiber, while offering

Crimpers operate with metal parts acceptable life. Materials ranging from moving next to other metal parts but not PTFE, carbon,

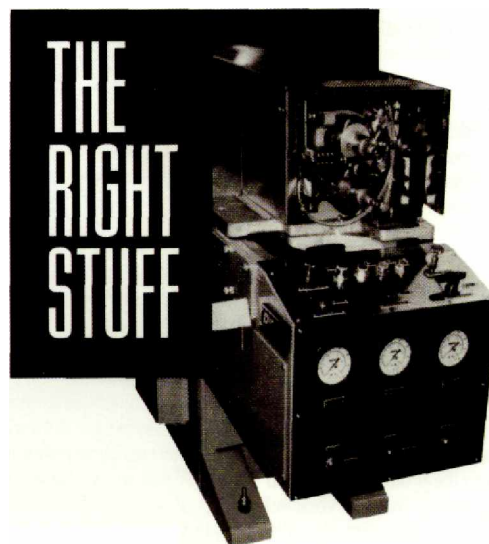

## CRIMPERS FOR CIGARETTE TOW, PRODUCTION, LABORATORY

The stuffing box is the core of crimping efficiency. DM&E offers precision stuffing boxes, with easy alignment of the rolls.

Crimpers feature...

- capacities to 500,000 total denier
- speeds of up to 450 meters per minute
- process flow—either vertical or horizontal

Contact us for details.

**DM&E** P.O. Box 580, Shelby, NC 28151-0580 Phone 704/482-8876 • FAX 704/484-8326

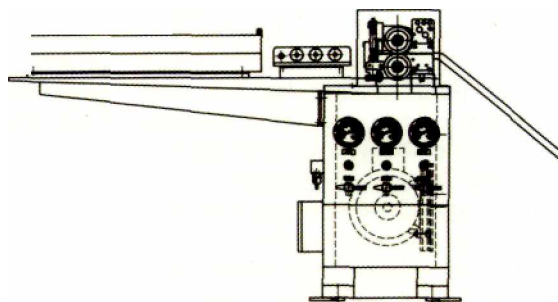

CT-10 Crimper

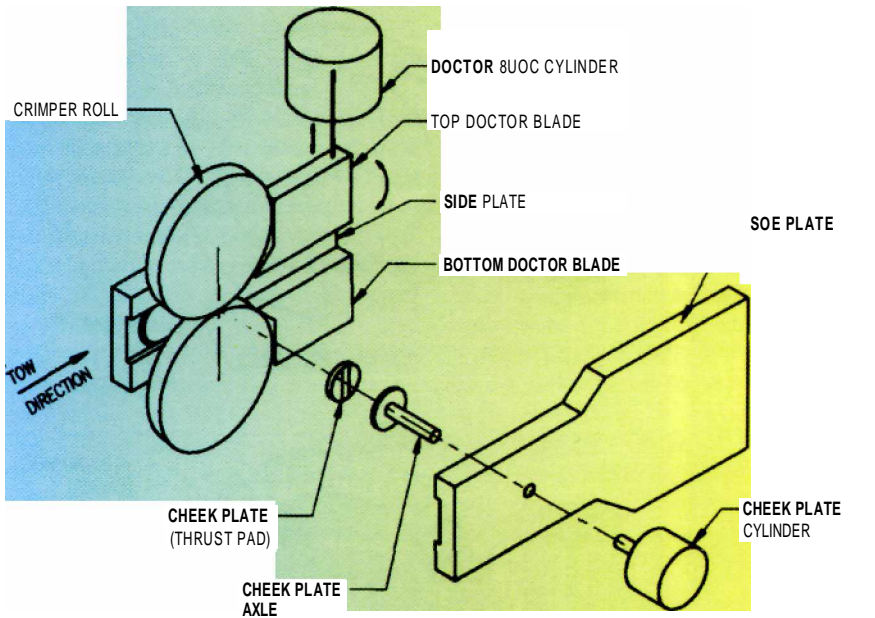

CMKR SnffFMB KK

*DM&E was incorporated in 1975 as a manufacturer's representative. In 1976, the company established its own manufacturing facility to more closely control quality and delivery.*

*The early 1980's saw rapid growth as the company worked with major domestic fiber producers to improve and expand its range of tow cutter repair services. Involvement in prototype development with other industries led to such diverse projects as the design and development of a compact, high output, internal combustion engine; process machinery for the metal working industry; and process equipment for the emerging compact disc industry.*

*As DM&E became the world's primary source for radial blade cutter repair, it was only a short step to use this expertise to develop their own cutter. The Model 40 light production cutter was followed by the Model 60 and Model 90 high production machines. Synthetic fiber tows from less than 100,000 denier to over 8,000,000 denier can now be processed on DM&E cutters and tension stands producing cut lengths from 3mm to 10 inches.*

*Just as work in cutter repair led to DM&E manufacturing its own line of cutters, work with crimper repair and refurbishment led to production of the DM&E crimper. The CL Series of crimpers is designed to meet light to medium production requirements.*

*DM&E now has installations in 16 countries, processing virtually all types of synthetic fibers for uses ranging from cigarette filters to disposable hospital gowns; from low melt-point tea bag sealing fibers to aramide brake lining.*

*Today, DM&E has a modern manufacturing facility with computer controlled machine tools backed by an expanding engineering staff. Growth into international markets and a continuing commitment to improving quality standards have led to the pursuit of ISO 9001 registration. DM&E looks to a future of expanded cutter and crimper product lines and extension of their partnership with fiber producers.*

brass, bronze and even ceramic have been used successfully.

### **The Art of Crimping**

Many experienced crimper supervisors can judge crimp levels accurately by simply looking at the product. Feel of the fiber will indicate fusion, broken filaments, or poor fiber cohesion. The supervisor can visually detect uneven tow presentation, roll slippage, or other problems. While the process engineer can dictate the general settings for operation, the experienced crimper supervisor is invaluable for trimming out the settings.

Tension control doesn't sound too important when you consider all the action taking place inside a crimper, but without proper tension control, uniform crimp cannot be attained.

It is essential that the incoming fiber be distributed uniformly across the roll nip area. If the fiber favors one side of the roll or the other, high crimp levels will exist on that side, while the other side will show a lazy crimp. Fiber producers manufacturing crimped continuous filament yarns, or manufacturing very light, precisely crimped fiber, may have an equivalent fiber film thickness of less than .005 in (.015 mm). If this thin fiber supply is the least bit uneven, slippage will result as the rolls are forced apart by the thick portion of the fiber supply. Eyeboards and sophisticated steering devices are frequently employed. While the more general crimping application does not experience the same magnitude of problem, the results are the same for poor tension control and poor fiber presentation to the crimper.

Perhaps one of the most commonly overlooked factors affecting crimper performance is the lubricating finish used on the fiber. Recall that the crimper is dependent upon the friction of the fiber against the surfaces of the stuffing box. Extremely high or low friction finishes will dramatically change crimper performance. Some finishes can actually cause the fiber in the stuffing box to move in large, irregular increments rather than almost continuous small movements. This results in periodic repetition of high and low crimp as the back pressure at the rolls is created then released. Many crimper supervisors have chased a change in crimper product quality without realizing that someone has changed the finish concentration or finish ingredients.

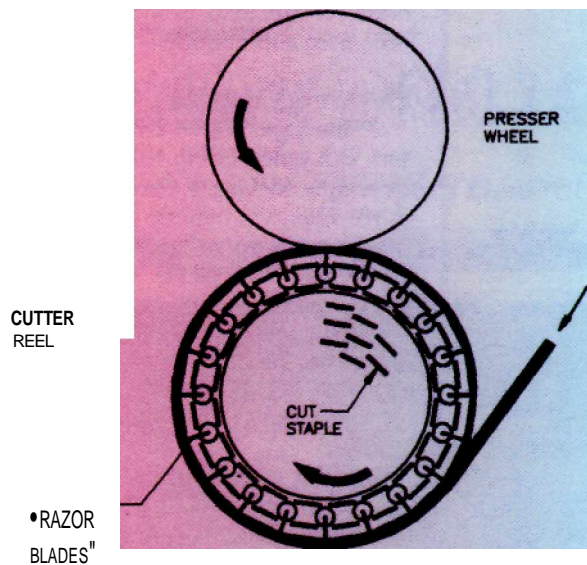

CUTTING PRINCIPLE

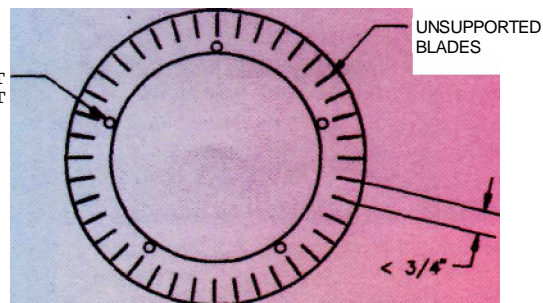
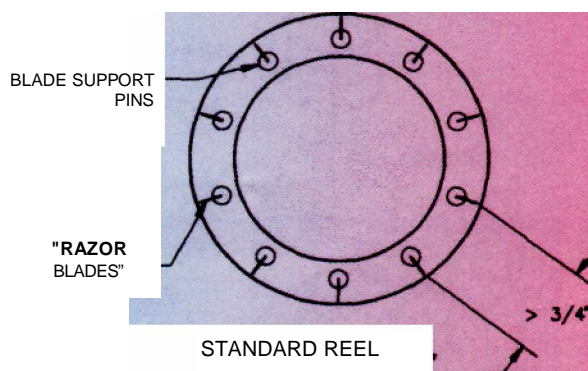

FLOCK REEL

### Crimper Maintenance

Crimper maintenance is a curse or a blessing, depending on the fiber producer's attitude. Proper maintenance by trained personnel yields longer uptime and consistent product quality. It is unfortunate that many plants attempt to maintain crimpers in conditions more suited to a blacksmith shop, by personnel whose training consisted of watching another untrained mechanic perform the same duty. If the crimper supplier offers a maintenance training course, take advantage of it.

Provide the correct tools. The crimper supplier should be able to supply a list of suggested tools, and may even have available specialized assembly tools. There are very few parts in a crimper, particularly those associated with the rolls and stuffing box, that have a total manufacturing tolerance greater than 1/5 the thickness of this page, parts like these never require a hammer or pipe wrench to assemble.

When purchasing a crimper, pay close attention to the maintenance required, consider accessibility of critical components, and ease of adjustment. Crimpers do require maintenance and adjustment; they cannot be set and forgotten.

### The Cutter

Staple fiber production usually

involves crimping. It always involves cutting. The most widely used tow cutter is the radial type invented by Garland Keith at Tennessee Eastman in the 1960's. The simplicity, accuracy, and flexibility of this cutter made it a world-wide success.

Radial blade theory calls for an infinitely large reel (cutter blade holder) and an equally large presser roll. This combination gives a configuration that gently presses the fiber into the cutting edge. In practice, large diameter presser rolls are used to provide gentler cutting action.

The radial blade cutter has three essential elements; the cutter reel; the presser roll; and tow presentation or guiding mechanism.

### Cutter Reels

The cutter reel supports a number of razor-type blades parallel to the support posts or pins that vary in shape, material, and quantity according to cut length, fiber type, and total denier being processed. Short staple fiber from 3/4 inch to 1 1/4 inches requires a shaped support post made of a very high strength stainless steel that presents a narrow face to the cut fiber. Long cut lengths for carpet staple can use a more robust design. Staple lengths between these two extremes require pin shapes and materi-

als specific to product characteristics.

Production of cut lengths under 3/4 inch requires a special reel without blade support posts. Generally referred to as flock reels, these units operate with reduced blade exposure since the unsupported blades become vulnerable to side loading.

Materials used in constructing cutter reels are generally stainless steel and "phenolic" for fiber contact surfaces and aluminum for other components. Some fiber types and cut lengths necessitate the use of heat-treatable stainless steel for durability. The use of carbon steel on fiber contact surfaces, though once common, is no longer an acceptable industry practice.

### Presser Rolls

The presser roll pushes against the fiber and begins the cutting process. Both theory and practice dictate as large a diameter presser roll as can be fitted within the cutter structure. Experience indicates a presser roll of the same diameter as the cutter reel is preferred. Presser rolls are exposed to very substantial loads and must be well supported. Their method of loading should result in a linear force always being applied to the fiber. In the event of broken or severely dulled blades, the presser roll should move away from the

blades and actuate some type of emergency cutter stop.

### **Tow Guidance & Presentation**

Often overlooked in cutter design, tow presentation is critical to producing quality cut fibers. Ideally, the tow band is a perfectly rectangular cross section as it enters the cutter, without touching anything downstream of the tension stand. In practice this does not occur and guides are required to shape and position the tow as it enters the cutter. A properly engineered tow presentation system must be capable of distributing the fiber from top to bottom in the band, raising, lowering, or narrowing the band, and finally containing the band so no fiber can escape the cutting action of the reel.

### **Tension Considerations**

To provide consistent cut length, tension should be as uniform as possible. Relaxing tension on crimped fiber slightly increases staple cut length; however, too little tension causes tow to accumulate in front of the rotating presser wheel and the presser wheel will eventually roll over a folded tow band. This doubled tow band results in excessive side loads on the cutting blades which may break. If the blades survive the side loading and cut the folded tow, both over- and under-length staple is now mixed into the product. Too much tension results in excessive motor load on the cutter. The tow may also slip around the reel causing variable cut lengths. Excessive tow tension may even cause the tow to be wrapped so tightly around the reel that the tow is cut prematurely.

Tension is cumulative. Every corner the tow turns and every surface the tow touches creates tension in the tow band. Many tow bands are made from smaller tow bundles supplied from a creel, and each of these smaller bundles contributes to total tow band tension. Tension of a moving tow band changes very little as line speed increases. A fishing scale connected to the tow band arid read as the tow is pulled by hand from a creel will indicate tension created by the creel and guides. Optimum cutter performance normally requires considerably more tension at the cutter than the creel friction can provide.

Tension necessary to start the tow band will be higher than moving tension. Tow supplied to the cutter directly from a crimper or drawstand tends to

be more uniform in tension than that supplied from a creel.

### **Controlling Tension with Tension Stands**

Tension stands are categorized as constant load or variable load stands. Each applies controlled tension to the row band for proper cutter performance.

Tension stands that provide constant load on the tow band add a fixed amount of tension to the accumulated tension in the band. For the constant load tension stand to provide the most uniform tension, it should provide a very high percentage of the total tension, since creel or upstream tension may vary during a production run.

Many fiber producers find it necessary to provide very uniform tension to the cutter to control staple length. Tension stands with electronic control systems are available to precisely regulate the tension to the cutter.

### **Capacity Considerations**

The total amount of tow to be cut, the cut length, and the cutting difficulty of the fiber are factors to consider when sizing cutters and cutter reels. The best selection is always a compromise of these variables.

Overall cutter size is determined by the total tow denier to be cut. A large cutter has sufficient power and suitable components to cut large tow bundles, but will also cut much smaller tow if required. However, it is poor economics to use a large cutter when a smaller cutter will work.

The total amount of tow that can be cut on any cutter is also influenced by the cut length. As the cut length becomes shorter, the capacity of the cutter reel is reduced. Short cuts that require flock type reels severely reduce capacity. If only short cut lengths are to be processed, there is no advantage in a large cutter since the cutter reel will limit total capacity.

Many fibers are difficult to cut and create unusually large loads on cutter components. It may be necessary to choose a larger cutter for its mechanical strength.

### **Cutter and Reel Maintenance**

Radial blade cutters are relatively simple machines. Good maintenance requires regularity more than sophistication. Failure to follow maintenance procedures, however, causes expensive repairs to cutter reels and creates off

grade product.

The most common maintenance failure involves the adjustment of the presser roll excessive pressure switch. If settings are not correct, substantial damage to the cutter reel and presser roll mechanism can result.

Cutter reel maintenance will affect quality. Fiber contact surfaces must be free of burrs and snag points. Blade slots must be cleaned of fiber waste periodically. Blade retainers must maintain firm pressure on the blades to prevent movement.

### **Cutter Blades**

There are reliable blade suppliers with the expertise to produce blades that meet process needs. Find one (or two), establish specifications, and perform periodic quality control inspections. Disposable blades are generally heat-treated stainless. Carbide blades are used for difficult-to-cut fibers and may be resharpened several times.

### **Synthetic Fiber Cutting in the Future**

The radial blade (or Keith) cutter as we know it is the best method of producing staple fiber available on the market today. It has some inherent deficiencies in producing certain cut lengths.

At one end of the spectrum are short cuts. Production can be maintained with multiple cutters and high line speeds. In the last five years, six millimeter cut lengths have become commonplace. Three millimeter is also being cut regularly, but this is very near the minimum cut length possible. Large denier tow bands are impossible to process.

The opposite end of the cut length spectrum is long staple common to the carpet industry. The primary problem here is "roping." Roping occurs as the cut fibers from adjacent blades entangle themselves and form long ropes.

The future will see specialized cutter designs tailored to the product. Cutter installations designed especially for economical production of short cut fiber are on the drawing board. Other cutter designs will aim at the problems generated by long staple. As the fiber producer targets customer needs more precisely, equipment will become more specialized. The days of the single cutter design filling all requirements are past.